

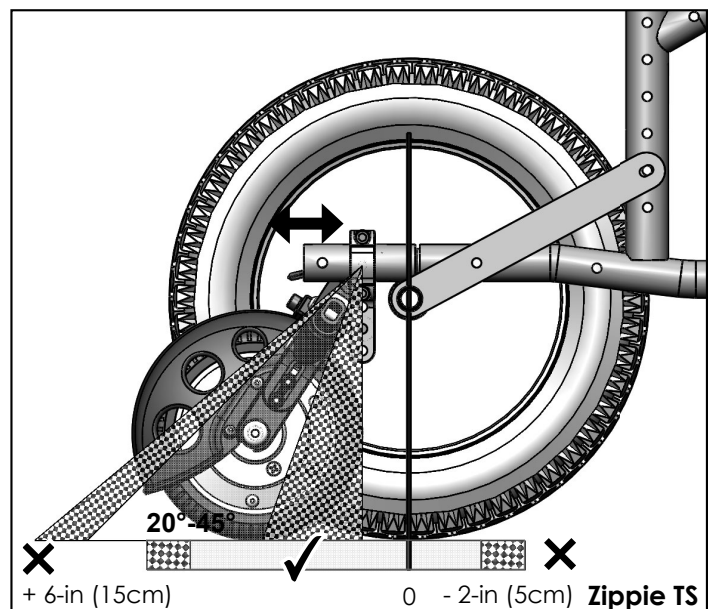

Please read these instructions carefully before beginning the assembly. Failure to understand and follow assembly instructions may result in injury to technician and/or end user and may void the warranty. If you have any questions call Sunrise Medical Technical Support at +1 (800) 333-4000.

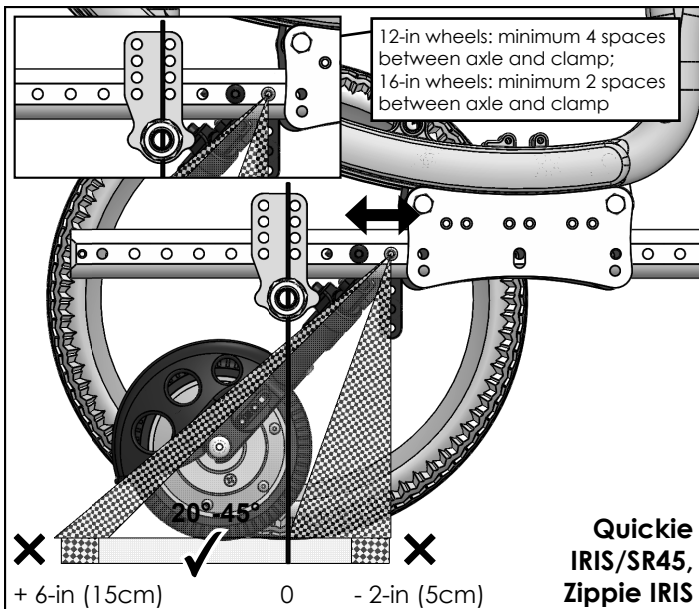
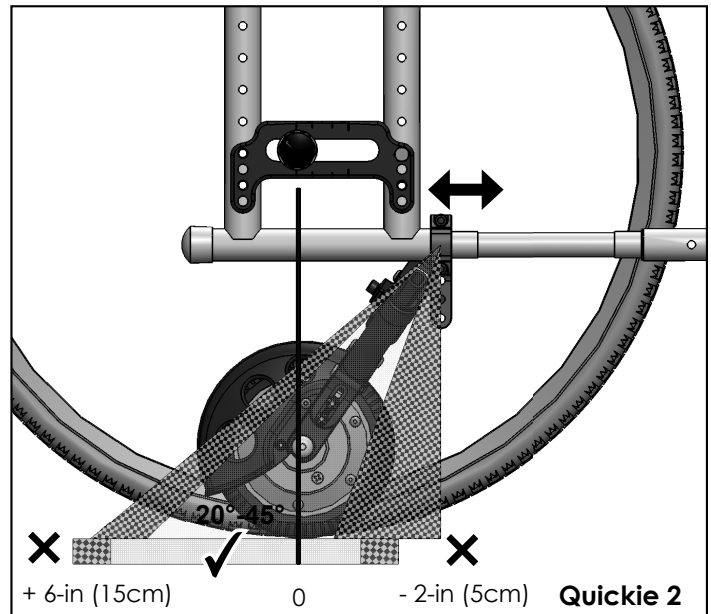
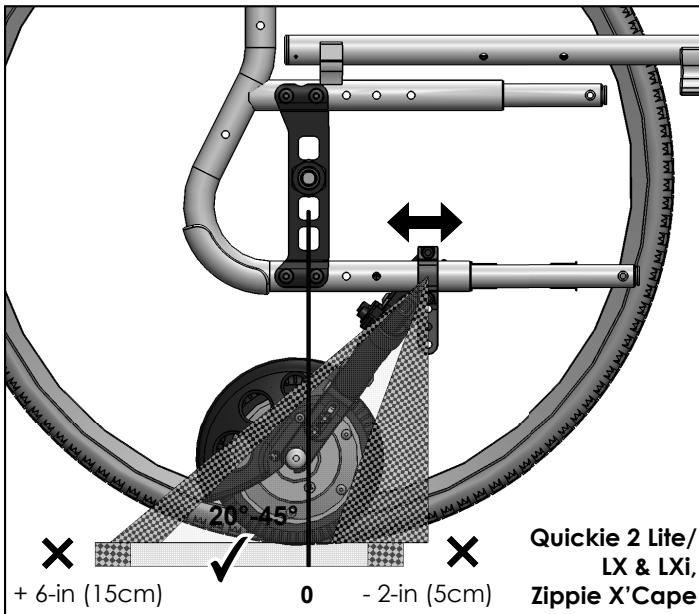

### ⚠️ DEALER/TECHNICIAN WARNING

Attention dealers and qualified technicians, do not operate or service this device without first reading the owner's manual. If you do not understand the instructions and warnings in the owner's manual please contact the Sunrise Medical Technical Service Department before operating and/or servicing the Empulse device. Failure to do so may result in damage and/or injury.

Find more information and important warnings in the device owner's manual or at: [www.SunriseMedical.com](http://www.SunriseMedical.com).

Sunrise Medical 2842 N. Business Park Ave Fresno, CA 93727 USA

Customer Service: +1(800) 333-4000  
or visit [www.SunriseMedical.com](http://www.SunriseMedical.com)

### Tools required

- |                                    |  |               |
|------------------------------------|--|---------------|
| 1. Socket wrench, sizes: 8mm, 15mm | 3. Hex Allen wrench, sizes: 2.5mm, 3mm, 4mm, 6mm | 4. Ruler      |
| 2. Angle square                    |  | 5. Protractor |

### WARNING

Fit the powered pushing device on a worktop, lifting platform, or workbench. We do not recommend that it is fitted and adjusted when on the floor.

### Non-Sunrise wheelchairs

- Match the rear frame style to images on page 1 to determine placement of clamps on wheelchair frame. Use the frame clamps that correctly fit the wheelchair's tubing size for frame clamps or frame hole spacing for bolts on clamps.

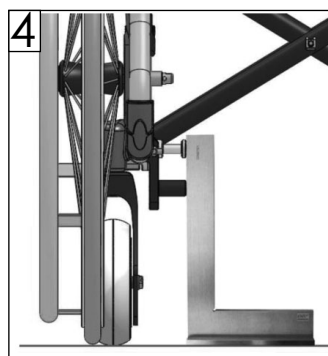
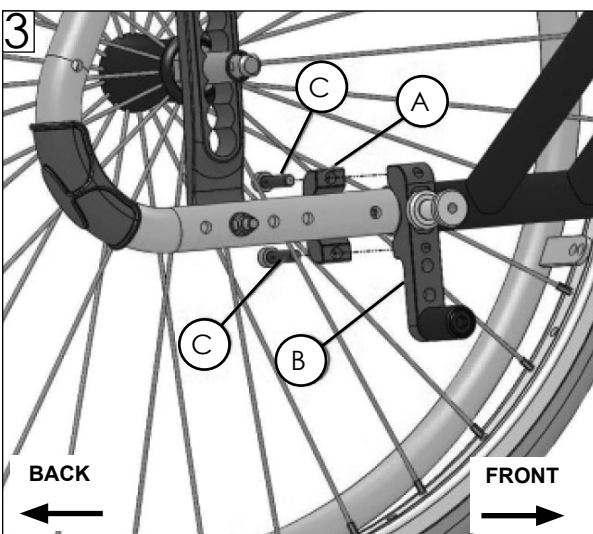
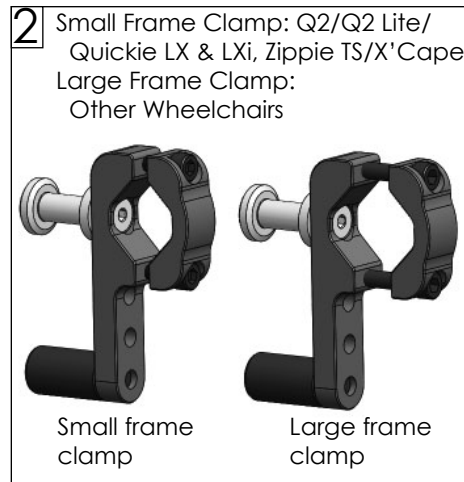
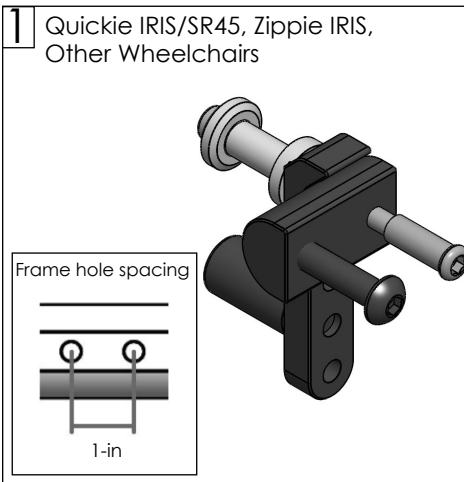

### A. Attaching the docking system (Fig. 1 - Fig. 4)

The docking system utilizes frame clamps that mount to the lower frame tube. There are three types:

- Bolt-on frame clamps (Fig. 1)
  - Small frame clamps: fits tubing size 7/8-in to 1-1/32-in [22-28mm] (Fig. 2)
  - Large frame clamps: fits tubing size 1-5/32-in to 1-1/4-in [29-32mm] (Fig. 2)
- Position the clamping jaws (A) around the lower frame tube from the outside and the bar (B) from the inside and screw both parts together with the screws (C). Only tighten the screws (C) gently, so that the clamp (A-B) can still be rotated and moved. Make this attachment on both sides in the same way. Do not overtighten.
  - Position the two clamps (A-B) exactly opposite each other so that both clamps are at the same height and position along tubing. Use a reference point from which you can measure (e.g. from the axle plate of the wheelchair to the clamp). If necessary, undo the screws (C) a little and move both clamps (A-B) so that they are at the same level. Then re-tighten the screws (C) gently.
  - Next, you must position the clamps (A-B) on both sides using an angle square, ensuring the clamps are still at right angles to the floor (Fig. 4). Adjust the clamps (A-B) to 90°, as shown. Once you have adjusted both sides to be at right angles, then torque the screws (C) to 5 Nm (44 in-lbs).



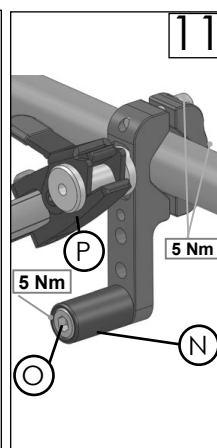
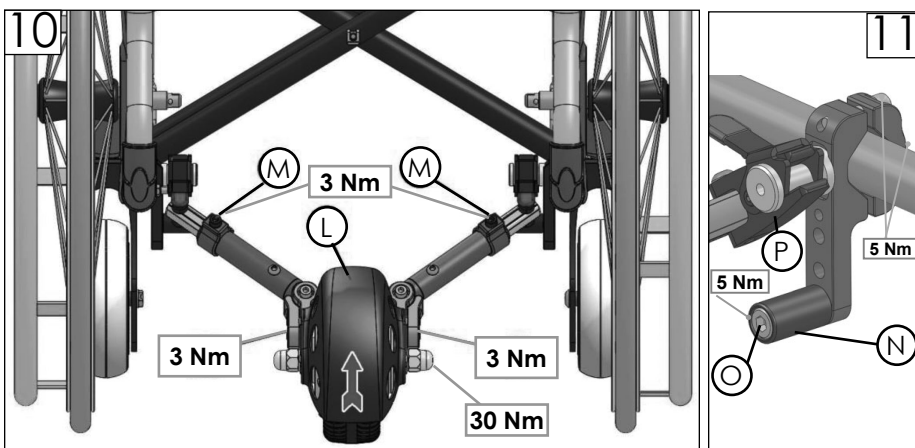
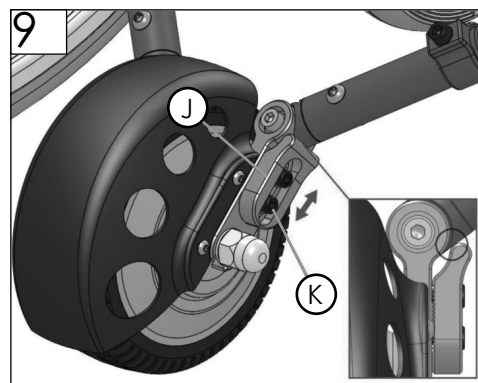
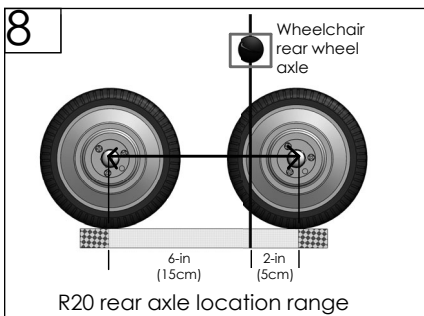
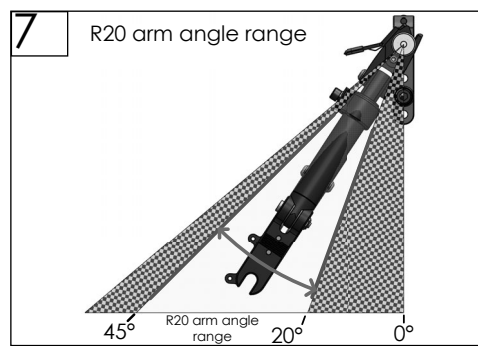
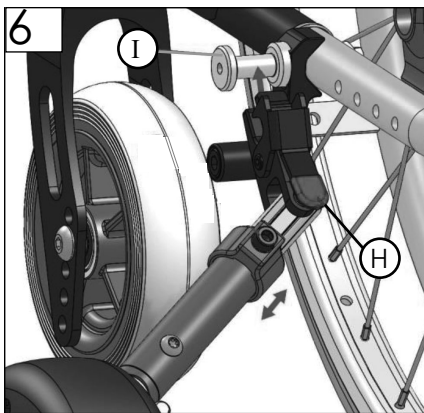
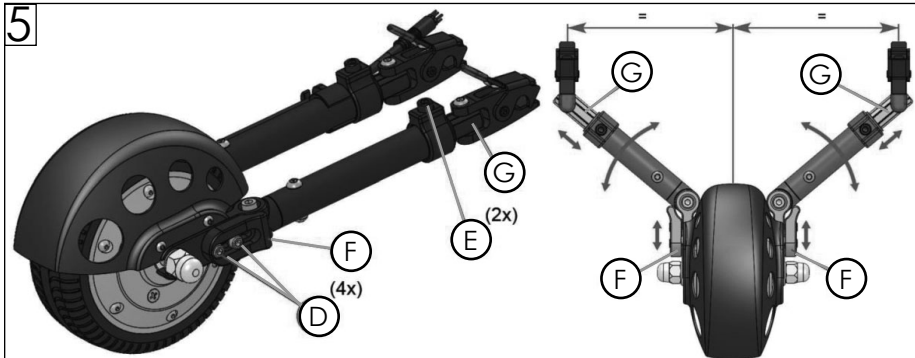

### B. Preparing the pushing device (Fig.5 - Fig. 11)

1. To prepare the pushing device, loosen screws (D) and (E) on both sides so jaws (F) and telescopic tube (G) can be adjusted.
2. To fit the pushing device, undo right and left arms by pressing release button (H) on the lever – and position over the docking pin (I).

#### ⚠ WARNING

The angle between the vertical and the pushing wheel must be minimum 20° and maximum 45°, and the R20 axle must be within -5cm to +15cm of the wheelchair axle. This guarantees that the pushing wheel will drive the wheelchair correctly (i.e. no slipping). (Fig. 7, Fig. 8)

3. Next, complete final adjustment and tightening of screws. If the wheel is positioned correctly, screws are only to be tightened as follows.

#### ⚠ WARNING

Please follow the sequence exactly!

#### ⚠ WARNING

Position the jaws so that the interlocking teeth are properly aligned!

4. To adjust the stop jaws (J), push jaws (J) forward right and left until they are up against the hinge (Fig. 9). Confirm the arm lengths are equal (Fig. 5) and within the arm angle range (Fig. 7). Then, torque screws (K) on both sides to 3 Nm [27 in-lbs].
5. By hand, gently press pushing unit forward (by pressing on mudguard (L)), so it is slightly under tension. Then, torque screws (M) to 3 Nm [27 in-lbs]. Once both sides are adjusted to be at right angles, torque screws (Fig. 3-C) to 5 Nm [44 in-lbs].

#### ⚠ WARNING

Engage the wheel locks on the wheelchair!

6. To adjust torque supports (stop) (N) on right and left, undo screw (O) and position torque supports (N) so the distance to the lock (P) is as small as possible. (Fig. 11)

Note: The pushing device should now be fitted in the center of the wheelchair and should be firm and rigid.

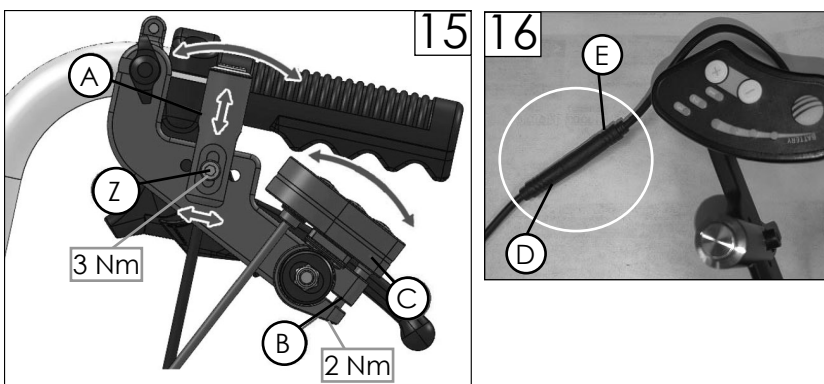
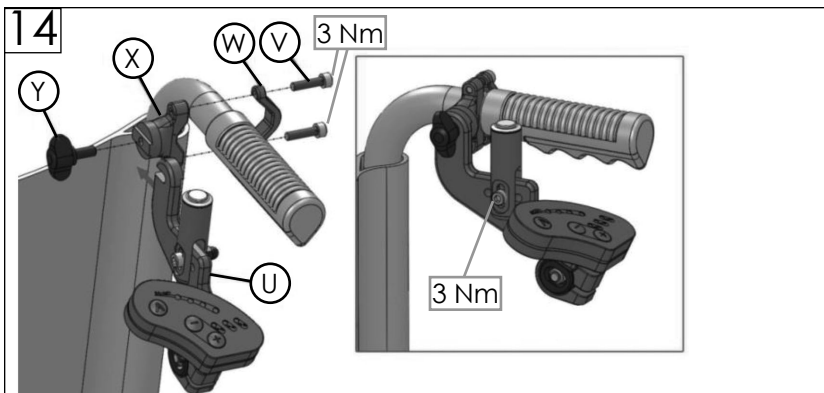
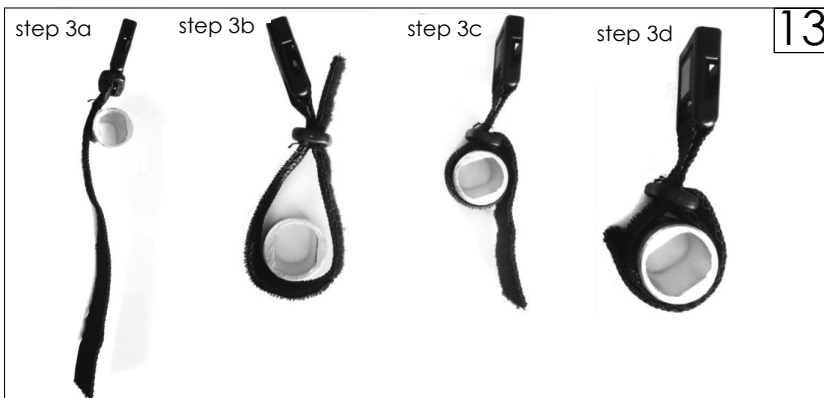

Torque Specifications: 2 Nm [18 in-lbs]; 3 Nm [27 in-lbs]; 5 Nm [44 in-lbs]; 30 Nm [266 in-lbs]



### C. Fitting the backpack (Fig. 12, Fig. 13)

1. Press button (Q) to undo the 4 retaining straps (R1-R4) on the backpack.
2. The two upper retaining straps (R1-R2) are fixed to the backrest tube.
3. The two lower retaining straps (R3-R4) can be fixed to a free part of the wheelchair (e.g. on the upper frame tube, backrest tube, or axle brackets). (Fig. 13)
  - a. Position the strap from one side of the tube, with the Velcro® facing outward.
  - b. Position the strap around the tube and pull through the loop.
  - c. Pull the strap through and fold backwards.
  - d. Position the strap completely around the tube so the Velcro® parts fit together.
4. Fitting the backpack onto the wheelchair:
  - a. Connect the four corners of the backpack with the buckle (Q) of the retaining straps.
  - b. Adjust the straps (S) to the required width for the wheelchair. Any surplus strap can be fixed using the retaining clips (T).

### D: Mounting and adjusting the control unit (Fig. 14-16)

1. Take the complete control unit (U) through the rear zip fastening of the backpack. Next, undo screws (V) and position gripper clamp (W) from the outside and beam clamp (X) from inside around the backrest tube. Torque screws (V) to 3 Nm [27 in-lbs]. (Fig. 14) 
2. Loosen wing bolt (Y) so control unit (U) can be fully removed and stored in the backpack. To do this, pull control unit (U) through the rear zip fastening of the backpack and store it in the right backpack pocket. (Fig. 14)
3. To adjust the height, position, and angle of the pushbutton (A), loosen or remove the screw fitting (Z). Adjust to ideal position, then screw the unit back on. Torque screw (Z) to 3 Nm [27 in-lbs]. (Fig. 15) 
4. To adjust the angle of the display (C), loosen screw (B). Adjust to ideal position, then screw the unit back on. Torque screw (B) to 2 Nm [18 in-lbs] (Fig. 15) 
5. Connect the control box cable (D) with the cable from the controller unit (E). (Fig. 16)

### ⚠ WARNING

Ensure plug connections are tight, in order to avoid any possible malfunctions due to insufficient contacts.

#### Torque Specifications:

2 Nm [18 in-lbs]; 3 Nm [27 in-lbs];  
5 Nm [44 in-lbs]; 30 Nm [266 in-lbs]